

Cellular Phone calling Detector

**Flashes a LED when detecting an incoming call
Powered by one 1.5V cell**

Circuit diagram:

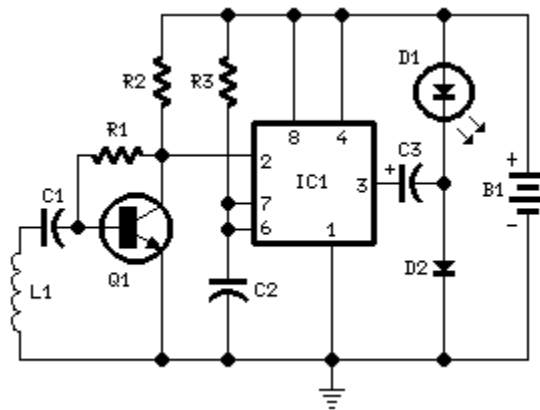

Parts:

R1 _____ 100K 1/4W Resistor

R2 _____ 3K9 1/4W Resistor

R3 _____ 1M 1/4W Resistor

C1,C2 _____ 100nF 63V Polyester Capacitors

C3 _____ 220µF 25V Electrolytic Capacitor

D1 _____ LED Red 10mm. Ultra-bright (see Notes)

D2 _____ 1N5819 40V 1A Schottky-barrier Diode (see Notes)

Q1 _____ BC547 45V 100mA NPN Transistor

IC1 _____ 7555 or TS555CN CMOS Timer IC

L1 _____ Sensor coil (see Notes)

B1 _____ 1.5V Battery (AA or AAA cell etc.)

Device purpose:

This circuit was designed to detect when a call is incoming in a cellular phone (even when the calling tone of the device is switched-off) by means of a flashing LED.

The device must be placed a few centimeters from the cellular phone, so its sensor coil L1 can detect the field emitted by the phone receiver during an incoming call.

Circuit operation:

The signal detected by the sensor coil is amplified by transistor Q1 and drives the monostable input pin of IC1. The IC's output voltage is doubled by C2 & D2 in order to drive the high-efficiency ultra-bright LED at a suitable peak-voltage.

Notes:

- Stand-by current drawing is less than 200 μ A, therefore a power on/off switch is unnecessary.
- Sensitivity of this circuit depends on the sensor coil type.
- L1 can be made by winding 130 to 150 turns of 0.2 mm. enameled wire on a 5 cm. diameter former (e.g. a can). Remove the coil from the former and wind it with insulating tape, thus obtaining a stand-alone coil.
- A commercial 10mH miniature inductor, usually sold in the form of a tiny rectangular plastic box, can be used satisfactorily but with lower sensitivity.
- IC1 must be a CMOS type: only these devices can safely operate at 1.5V supply or less.
- Any Schottky-barrier type diode can be used in place of the 1N5819: the BAT46 type is a very good choice.